



# DIRECTV® WIRELESS VIDEO BRIDGE GEN2

Product Manual



## Introduction

Product Manuals are intended to help customers understand the workings of the hardware devices. This Product Manual is posted online at **att.com** and at **directv.com/manuals** for customer access.

The purpose of this document is to communicate information associated with the Wireless Video Bridge Gen2 and to provide an overview addressing specific functions of the device.

## Safety information can be found in the Appendix

Before using the equipment, read the Important Safety Instructions on pages 14-16. This manual outlines safeguards information. The safety information contained in this manual was developed and provided solely by the manufacturer.

## TABLE OF CONTENTS

<b>I. Overview</b> .....	<b>5</b>
A. Wireless Video Bridge .....	5
<b>II. Hardware Information</b> .....	<b>6</b>
A. Wireless Video Bridge .....	6
1. Front Panel.....	6
2. Rear Panel.....	7
<b>III. Minimum Requirements</b> .....	<b>9</b>
<b>IV. Features</b> .....	<b>10</b>
A. 802.11ac Support .....	10
B. MoCA 2.0.....	10
C. Wireless Repeater Functionality.....	10
D. Wireless Protected Setup.....	10
<b>V. Installation Options</b> .....	<b>10</b>
A. Tabletop Installation .....	10
B. Wall Mount Installation.....	10
<b>VI. Troubleshooting</b> .....	<b>12</b>
A. WVB2 LED Troubleshooting .....	12
<b>VII. Appendix</b> .....	<b>13</b>
A. Federal Communications Commission Interference Statement.....	13
B. Safety & Care .....	14
C. Caution—Additional Safety Instructions.....	16
D. Limited 90-Day Warranty .....	16

## FIGURES

Figure 1: WVB2—Front Panel.....	6
Figure 2: WVB2—Rear Panel.....	7
Figure 3: WVB2—Side View.....	8
Figure 4: EPS10 Power Supply.....	8
Figure 5: Tabletop Installation.....	10
Figure 6: Wall Mount Installation Hardware .....	10
Figure 7: Slots for Mounting.....	11
Figure 8: Attaching the Mounting Plate for Wall Mount Installation .....	11

Terminology	
Term	Description
WVB	Wireless Video Bridge

## I. OVERVIEW

### A. WIRELESS VIDEO BRIDGE

The Wireless Video Bridge Gen2 (WVB2) is a second-generation Wireless Video Bridge. It is a direct replacement of the WVB Gen1 and has enhanced networking features.

The WVB2 provides the ability to stream DIRECTV programming from a Genie server to the Genie Mini (C41W or higher) client wirelessly, creating a private network only accessible to DIRECTV products. This allows for video distribution throughout the home without the use of coaxial or CAT5 cables at every TV.

## II. HARDWARE INFORMATION

### A. WIRELESS VIDEO BRIDGE

#### 1. Front Panel



FIGURE 1: WVB2—FRONT PANEL

#### **The front panel contains:**

- Multicolor status indicator LED

The WVB2 is to be installed vertically (it is not to be placed in a horizontal position).

The WVB2 can be wall-mounted using the mounting bracket provided. When using the mounting bracket, the WVB2 should remain positioned upright (not upside down). *See page 10 for mounting instructions.*

## 2. Rear Panel



FIGURE 2: WVB2—REAR PANEL

### The rear panel contains:

- Red reset button
- Add Client button
- Ethernet port
- Two satellite in F connectors
- DC power inlet connector matching EPS10 external power supply
- Green power indicator LED



FIGURE 3: WVB2—SIDE VIEW



FIGURE 4: EPS10 POWER SUPPLY

WVB2 Specifications
<b>Size and Weight</b>
• Height: 182mm
• Width: 190mm
• Depth: 182mm
• Weight: 12.05 oz.



### III. MINIMUM REQUIREMENTS

The minimum requirements for a Wireless Video distribution are:

- SWiM installation
- Genie server (HR34/HR44/HR54/H44+HDD)
- Wireless Video Bridge
- At least one wireless Genie Mini Client
- EPS10 (DC 25.2V) External Power Supply

## IV. FEATURES

Functionally, the WVB Gen2 is identical to the WVB Gen1 with the exception of the following features:

### A. 802.11AC SUPPORT

802.11ac is the latest IEEE Wi-Fi® standard, which provides increased bandwidth and additional throughput over increased range compared to 802.11n (on which WVB Gen1 is based). Increased throughput is required to sustain the level of video traffic required to support more concurrent clients, which are a feature of the HS17 family of products with up to seven HD clients supported or two Wireless 4K clients and one Wireless HD client.

### B. MoCA 2.0

MoCA 2.0 allows for increased frequency range and channel bandwidth, which leads to increased throughput over greater distances in comparison to MoCA 1.1. MoCA 2.0 is also backwards compatible with MoCA 1.1 and will therefore allow for operability with existing MoCA 1.1-compliant products.

### C. WIRELESS REPEATER FUNCTIONALITY

The WVB Gen2’s ability to act as a wireless repeater means it can offer a wireless solution for extending the range of the internal WVB of the HS17.

### D. WIRELESS PROTECTED SETUP

The WVB Gen2 has an Add Client button that will primarily be used with the Genie 2 (HS17) set-top box, eliminating the need to add the RVU client through the “Add Client” screen. If the user chooses, they also have the option of adding an RVU client through the “Add Client” screen, just like the WVB Gen1.

## V. INSTALLATION OPTIONS

### A. TABLETOP INSTALLATION

The DIRECTV Wireless Video Bridge unit can be placed directly on a flat surface. Follow the IMPORTANT SAFETY INSTRUCTIONS to find a proper place for the safe use of this product.

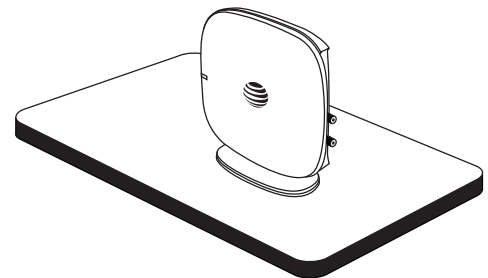

FIGURE 5: TABLETOP INSTALLATION

### B. WALL MOUNT INSTALLATION

The DIRECTV Wireless Video Bridge unit can also be mounted horizontally to a wall using a mounting unit.

- Two M4 x 20mm pan head screws (thread type: tapping) are included for wall mounting.
- Two expansion anchors are included for wall mounting into drywall.

*Note: If mounting to a stone/brick/cement wall, you will need suitable masonry plugs.*

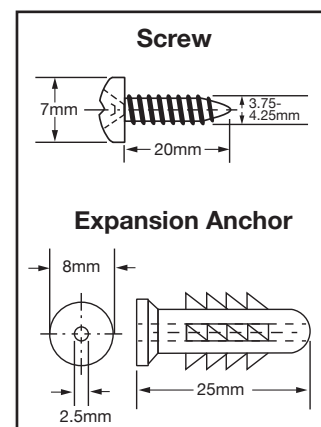

FIGURE 6: WALL MOUNT INSTALLATION HARDWARE

## V. INSTALLATION OPTIONS *continued*

### B. WALL MOUNT INSTALLATION *continued*

1. Determine location.
  - a. Ensure that the mounting location is free from hazards such as electric cables, wires, pipes, ducts, etc.
2. Drill pilot holes.
  - a. *If mounting in a stud partition wall:* Locate the studs in the wall. At least one of the mounting screws should be attached to a wooden stud. (You should use an expansion anchor for any holes that are not directly in a stud. Do NOT use the expansion anchor for any holes that are directly into a stud.)
  - b. Hold the mounting plate up (horizontally) to the wall and mark the location of the two pilot holes, making sure they are level. The holes should be spaced 55mm (about 2.17") apart horizontally.
  - c. Drill two pilot holes 26mm (about 1") deep using a 3.6mm (1/8") drill bit. If using an expansion anchor, drill that hole using an 8mm (1/4") drill bit.
  - d. For any holes using an expansion anchor, lightly tap the expansion anchor into the hole using a hammer.
3. Attach the mounting plate to the wall.
  - a. Place the mounting plate against the wall, aligning the holes.
  - b. Drive the screws through the mounting plate to be fastened and into the holes in the wall. (Step 1 below.)
4. Attach the unit to the mounting plate.
  - a. Align the two slots at the bottom of the unit with the two pins on the mounting plate. (Step 2 below.)
  - b. Slide the unit until it locks in place. (Step 3 below.)

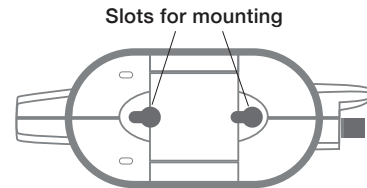

FIGURE 7: SLOTS FOR MOUNTING

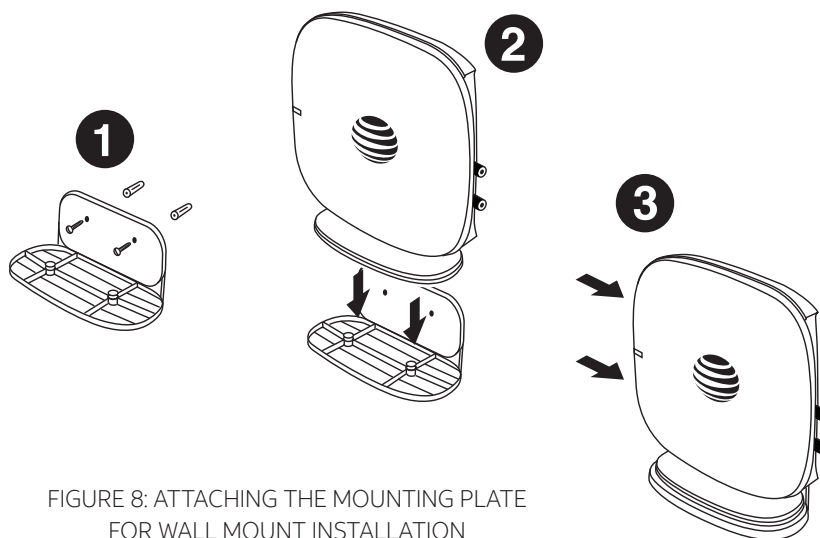













FIGURE 8: ATTACHING THE MOUNTING PLATE FOR WALL MOUNT INSTALLATION

## VI. TROUBLESHOOTING

### A. WVB2 LED TROUBLESHOOTING

LED State	Description
 Off	Device not powered
 Blinking Blue	Booting up Start within 10 seconds of power ON
 Solid Blue	Normal operation Wireless clients (C61W) should have a connection to the Genie server
 Blinking Green	Bridge in Survey/Beacon Mode MoCA network connected No communication from Genie server to the WVB2
 Solid Green	Good connection to the Genie server but no clients paired with the WVB2
 Blinking Yellow	No MoCA network detected [Note: Although issues will be seen on the wireless client (C61W), the issues are not with the communication between the WVB2 and C61W]
 Solid Yellow	MoCA network established MoCA Phy Rate < 180 Mbps [Note: Although issues will be seen on the wireless client (C61W), the issues are not with the communication between the WVB2 and C61W]
 Blinking Green and Yellow	Wireless Video Bridge Survey/Beacon Mode No MoCA network established
 Blinking Green and Blue	Wireless Client Add Mode
 Solid Red	The WVB2 has a good connection to the Genie server; however, there is a poor wireless connection to one or more wireless clients (C61W)
 Blinking Red	Device error detected

## VII. APPENDIX

### A. FEDERAL COMMUNICATIONS COMMISSION INTERFERENCE STATEMENT

This equipment has been tested and found to comply with the limits for a Class B digital device, pursuant to Part 15 of the FCC Rules. These limits are designed to provide reasonable protection against harmful interference in a residential installation. This equipment generates, uses, and can radiate radio frequency energy and, if not installed and used in accordance with the instructions, may cause harmful interference to radio communications. However, there is no guarantee that interference will not occur in a particular installation. If this equipment does cause harmful interference to radio or television reception, which can be determined by turning the equipment off and on, the user is encouraged to try to correct the interference by one of the following measures:

- Reorient or relocate the receiving antenna.
- Increase the separation between the equipment and receiver.
- Connect the equipment into an outlet on a circuit different from that to which the receiver is connected.
- Consult the dealer or an experienced radio/TV technician for help.

FCC Caution: Any changes or modifications not expressly approved by the party responsible for compliance could void the user's authority to operate this equipment.

This device complies with Part 15 of the FCC Rules. Operation is subject to the following two conditions: (1) This device may not cause harmful interference, and (2) this device must accept any interference received, including interference that may cause undesired operation.

This device is restricted for indoor use.

#### **IMPORTANT NOTE:**

##### **FCC Radiation Exposure Statement:**

This equipment complies with FCC radiation exposure limits set forth for an uncontrolled environment. This equipment should be installed and operated with minimum distance of 20cm between the radiator and your body.

## B. SAFETY & CARE

As part of our ongoing commitment to help conserve energy and reduce waste, we have made user manuals available online where you can conveniently access them at any time. Please go to [att.com](http://att.com) or [directv.com/manuals](http://directv.com/manuals)

Your DIRECTV® Receiver has been designed and manufactured to stringent quality and safety standards. You should, however, be aware of the following important precautions for safe and optimal use of the equipment. Meaning of symbols printed on the rear panel of the product:



This symbol indicates that there are important operating and maintenance instructions in the literature accompanying this unit.



This symbol indicates that dangerous voltage constituting a risk of electric shock is present within this unit.

### Important Safety Instructions

1. Read these instructions.
2. Keep these instructions.
3. Heed all warnings.
4. Follow all instructions.
5. Do not use this apparatus near water.
6. Clean only with dry cloth.
7. Do not block any ventilation openings. Install in accordance with the manufacturer's instructions.
8. Do not install near any heat sources such as radiators, heat registers, stoves, or other apparatus (including amplifiers) that produce heat.
9. Do not defeat the safety purpose of the polarized or grounding-type plug. A polarized plug has two blades with one wider than the other. A grounding-type plug has two blades and a third grounding prong. The wide blade or the third prong are provided for your safety. If the provided plug does not fit into your outlet, consult an electrician for replacement of the obsolete outlet.
10. Protect the power cord from being walked on or pinched, particularly at plugs, convenience receptacles, and the point where they exit the apparatus.
11. Use only attachments/accessories specified by the manufacturer.
12. Use only with the cart, stand, tripod, bracket, or table specified by the manufacturer, or sold with the apparatus. When a cart is used, use caution when moving the cart/apparatus combination to avoid injury from tip-over.
13. Unplug this apparatus during lightning storms or when unused for long periods of time.
14. Refer all servicing to qualified service personnel. Servicing is required when the apparatus has been damaged in any way, such as power-supply cord or plug is damaged, liquid has been spilled or objects have fallen into the apparatus, the apparatus has been exposed to rain or moisture, does not operate normally, or has been dropped.
15. Use only the power supply (power cord) that came with your DIRECTV® Receiver. Failure to use the authorized power supply (power cord) may cause electric shock, fire, bodily injury, and/or property damage. If the power supply (power cord) becomes damaged or needs to be replaced, please contact DIRECTV Customer Service to obtain an authorized replacement.



**WARNING:** To reduce the risk of fire or electronic shock, do not expose this product to rain or moisture. The apparatus shall not be exposed to dripping or splashing and no objects filled with liquids, such as vases, shall be placed on the receiver.



**CAUTION:** To reduce the risk of electric shock, *do not remove cover* (or back).  
No user serviceable parts inside.  
Refer servicing to qualified service personnel.

**IMPORTANT:** Be sure not to place your DIRECTV® Receiver near anything WET or HOT.  
If this product is rated at 240VAC, a suitable attachment plug should be used.

**CAUTION:** Avoid moisture to reduce the risk of fire or electric shock. The DIRECTV® Receiver should not be used near water (for example, kitchen sink, bathtub, pool, damp basement). Also, never spill liquid on the receiver, and do not place vases or other vessels containing liquid on top of it.

**TIP:** We highly recommend plugging the DIRECTV® Receiver into a surge protector to prevent damage from fluctuations in your power supply.

*Note to Satellite Dish Installer: This reminder is provided to call your attention to articles 810 and 820 of the 2011 National Electrical Code. Refer to article 810, in particular 810-1 and 810-15, for required grounding of the metal structure of the dish antenna. Refer also to the 810-2 which, by reference to article 820, requires that the satellite dish coaxial cable shield be connected to the grounding system of the building as close to the point of cable entry as practical.*

- Ensure proper ventilation—the vent slots on the DIRECTV® Receiver must be left uncovered to allow proper airflow to the unit. Blocking the airflow to the unit could impair performance or damage your receiver and other components.
- Do not stack electronic components or other objects on top of the DIRECTV® Receiver. Also, do not stack the receiver on top of a hot component such as an audio power amplifier.
- Protect your components from power surges by connecting all the components before plugging any power cords into the wall outlet. Use of a surge protector is also recommended.
- Don't overload power outlets or extension cords, which can result in the risk of fire or shock. It's also important to use only the type of power source indicated on the marking label or in this manual.
- Avoid audio hum or interference by inserting all cable plugs firmly into their jacks. Also, place Audio/Video (A/V) cables to the sides of the TV back panel rather than down the middle once connected. Try not to coil any twin-lead cables, and keep them away from A/V cables as much as possible.
- Never insert objects of any kind into any openings in the DIRECTV® Receiver (other than the DIRECTV® Access Card as detailed in this manual).
- Place it on a flat, hard surface—do not operate the DIRECTV® Receiver on a carpet or other padded surface.
- Always unplug your DIRECTV® Receiver before moving it.
- Always unplug the DIRECTV® Receiver, TV and other equipment before you connect or disconnect any cables.
- The only way to disconnect the DIRECTV® Receiver from the power supply is to remove the power cord. The DIRECTV® Receiver unit must therefore be installed next to the power point, which must be easily accessible.
- **CAUTION:** Electric Shock—never attempt to disassemble the DIRECTV® Receiver yourself; always take it to a qualified service person when repair is required. Opening or removing covers may expose dangerous voltage or other risks, and incorrect reassembly can cause shock when receiver is subsequently used. Attempted self-repair may also void your warranty. Changes or modifications not expressly approved by the party responsible for compliance (by the warranty or by the manufacturer) could void the user's authority to operate the equipment.
- Do not drop your DIRECTV® Receiver, and always move it with care.
- Have your DIRECTV® Receiver professionally serviced (do not attempt to service it yourself).
- Any changes or modifications in the construction of this device which are not expressly approved by the party responsible for compliance could void the user's authority to operate the equipment.
- If you move your DIRECTV® Receiver between locations at different temperatures, allow it to reach room temperature before you apply power to it.
- Do not pick up or otherwise move your DIRECTV® Receiver while it is connected to the AC power supply. If you want to move your DIRECTV® Receiver, first disconnect it, then wait at least 30 seconds before continuing.
- **CAUTION:** To reduce the risk of fire, use only No. 26 AWG or better telecommunications line cord.
- **CAUTION:** Replace remote control batteries with same or equivalent type. There is danger of explosion if batteries are incorrectly replaced.
- For your information: The identification sticker can be located behind the small door on the front panel of your receiver.
- The telecommunication network voltage used is the category number 3.
- See product bottom for important safety information.

### **C. CAUTION—ADDITIONAL SAFETY INSTRUCTIONS**

The WVB2 requires the UL Listed EPS10-15 or EPS10-36 External Power Supply having the following rating: Input rating 120Vac, 60Hz, 1.8A, output rating 25.2Vdc, 2.86A, 72W.

### **D. LIMITED 90-DAY WARRANTY**

DIRECTV warrants your DIRECTV® Receiver and any included accessories against defects in material or workmanship for a period of ninety (90) days after the date of acquisition.

#### **Who Is Covered?**

You must have proof of acquisition to receive warranty service. A receipt or other document showing that you acquired the product is considered proof of acquisition. THIS LIMITED WARRANTY EXTENDS ONLY TO THE ORIGINAL CONSUMER ACQUIRER OR ANY PERSON RECEIVING THE DIRECTV® RECEIVER AS A GIFT FROM THE ORIGINAL CONSUMER ACQUIRER AND TO NO OTHER ACQUIRER OR TRANSFEREE. THIS WARRANTY DOES NOT EXTEND TO COMMERCIAL USERS. THIS PRODUCT IS NOT AUTHORIZED FOR USE OUTSIDE THE UNITED STATES AND ANY SUCH USE VOIDS THIS WARRANTY.

#### **What Is Covered?**

Warranty coverage begins the day you acquire the product. For ninety (90) days from the acquisition date, at the option of DIRECTV, the DIRECTV® Receiver will be repaired or replaced with a new, repaired, refurbished or comparable product (whichever is deemed necessary) if it becomes defective or inoperative. This exchange is done without charge to you for parts and labor. You will be responsible for the cost of shipping to and from the location designated by DIRECTV. If DIRECTV cannot reasonably repair or replace the Receiver then DIRECTV may, at its sole discretion, refund the price you paid for the product or the current retail price of the product.

All products, including replacement products, are covered only for the original warranty period. When the warranty on the original product expires, the warranty on the replacement product also expires. After ninety (90) days from the date of acquisition, you pay for the replacement of all parts, and for all labor charges.

SOME STATES DO NOT ALLOW LIMITATIONS ON HOW LONG AN IMPLIED WARRANTY LASTS, SO THE ABOVE LIMITATION MAY NOT APPLY TO YOU.

#### **What Is Excluded?**

Your warranty does NOT cover:

Labor charges for installation or setup of the product.

Installation, performance of, or repair of: audio/video cabling, telephone line, or accessory attachments used with the product.

Product replacement because of misuse, accident, lightning damage, unauthorized repair, or other cause not within the control of DIRECTV. Incidental or consequential damages resulting from the product. SOME STATES DO NOT ALLOW THE EXCLUSION OF INCIDENTAL OR CONSEQUENTIAL DAMAGES, SO THE ABOVE EXCLUSION MAY NOT APPLY TO YOU. Any modifications or other changes to the product, including but not limited to software or hardware modification in any way other than as expressly authorized by DIRECTV, will void this limited warranty.

Except in the case of hardware or software provided by DIRECTV, installing software modifications, “hacks” or utilizing service access or “back doors” will void this limited warranty.

Reception transmission problems caused by signal conditions, telephone line, or cable or antenna systems outside the unit. A product that has been modified or adapted to enable it to operate in any country other than the country for which it was designed, manufactured, approved and/or authorized, or repair of products damaged by these modifications. A product used for commercial or institutional purposes.



DIRECTV makes no warranty that the access connection will be a local (not long distance) phone call.

The continued provisioning of any of the programming and other services delivered through the Receiver including but not limited to television programming, show information, program guide data, and scheduling information.

### **Make Sure You Keep...**

Please keep your receipt or other document showing proof of acquisition. Attach it to this User Guide and keep both nearby. Also keep the original box and packing material in case you need to return your product.

### **Before Requesting Repair Service...**

Please check the Troubleshooting section of this guide. This may save you a call to DIRECTV Customer Care.

### **To Get Warranty Service**

Warranty service will be provided by DIRECTV. If you believe you need service for your Receiver, contact DIRECTV at 1-800-DIRECTV. A representative will go through a diagnostic checklist with you. If it is determined that the product needs to be returned for service or exchanged, you will receive a return authorization number. The representative will give you complete shipping details.

### **To Get Out-of-Warranty Service**

To obtain out-of-warranty service, contact DIRECTV at 1-800-DIRECTV for information on the possibility of and any costs for repair or replacement of out-of-warranty products.

ALL WARRANTIES IMPLIED BY LAW, INCLUDING ANY IMPLIED WARRANTIES OF MERCHANTABILITY AND FITNESS FOR A PARTICULAR PURPOSE ARE EXPRESSLY LIMITED TO THE DURATION OF THIS EXPRESS LIMITED WARRANTY.

WITH THE EXCEPTION OF ANY WARRANTIES IMPLIED BY THE LAW OF ANY STATE OF THE U.S.A., THIS EXPRESS LIMITED WARRANTY IS EXCLUSIVE AND IN LIEU OF ALL OTHER WARRANTIES, GUARANTEES, AGREEMENTS AND SIMILAR OBLIGATIONS OF DIRECTV. REPAIR OR REPLACEMENT AS PROVIDED IN THIS LIMITED WARRANTY IS THE EXCLUSIVE REMEDY UNDER THIS LIMITED WARRANTY. IN NO EVENT WILL DIRECTV BE LIABLE FOR ANY AMOUNT GREATER THAN THE RETAIL PRICE OF THE DIRECTV® Receiver. DIRECTV SHALL NOT BE LIABLE FOR ANY INCIDENTAL OR CONSEQUENTIAL DAMAGES FOR BREACH OF ANY EXPRESS OR IMPLIED WARRANTY ON THE DIRECTV® Receiver.

SOME STATES DO NOT ALLOW LIMITATIONS ON WARRANTIES, SO THE ABOVE LIMITATIONS MAY NOT APPLY TO YOU. THIS WARRANTY GIVES YOU SPECIFIC LEGAL RIGHTS. YOU MAY HAVE OTHER RIGHTS WHICH VARY FROM STATE TO STATE.

### **DIRECTV**

**2230 E. Imperial Hwy**

**El Segundo, CA 90245**

**1-800-DIRECTV**